

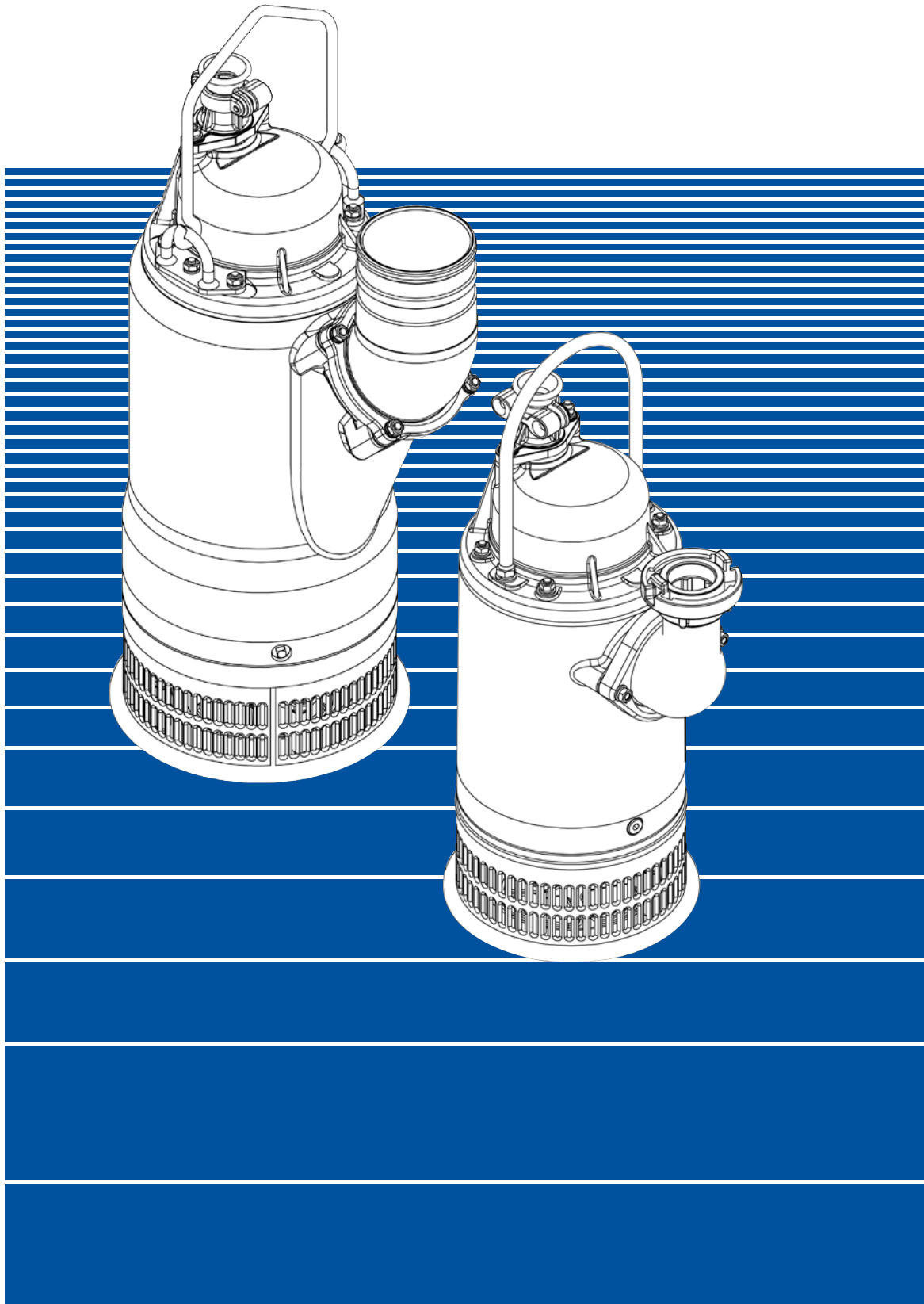

Submersible pumps

# KDFU



## Application

Submersible sludge pumps are destined for conveying water polluted with a content of sludge, clay, sand, crushed stones and similar materials of abrasive effects, with total content of max 30% by weight.

Max. temperature of a pumped liquid ..... 40°C  
 Max. density of a pumped liquid..... 1,200 kg.m<sup>-3</sup>  
 Value of pH ranging ..... from 6.5 to 7.5 pH  
 Max. submersion of pump set ..... 10 m

Besides their vertical working position these pumps can be operated in both horizontal and inclined working positions.

They are fully convenient for using in civil engineering, for earthwork and land reclamation, removal of consequences of floods, e.g. drainage of flooded cellars, basements, and so on.

**The pumps in their standard workmanship version are not suited for pumping water containing oils and hydrocarbons. Pumps destined for conveying these liquids can be delivered in their special design modifications by agreement with the producer.**

## Design

These pumps are of single stage type and form a compact closed set with an electric motor. The rotor is supported on antifriction, rolling-contact bearings with grease lubrication. In the motor winding there are bimetallic thermal receptors protecting them from damage.

From water penetration from the hydraulic part the electric motor is provided with a mechanical seal with a permanent oil closure and lubrication from oil cup.

## Material options

The pump main parts are of the following construction materials:

Impeller - tool steel  
 Shaft - corrosion-proof steel  
 Impeller nut - corrosion-proof steel  
 Sleeve, external bolts - corrosion-proof steel

A major part of the pump constructional parts is of light aluminium alloy and of steel rubberized pressed pieces being characterized by significant mechanical ruggedness.

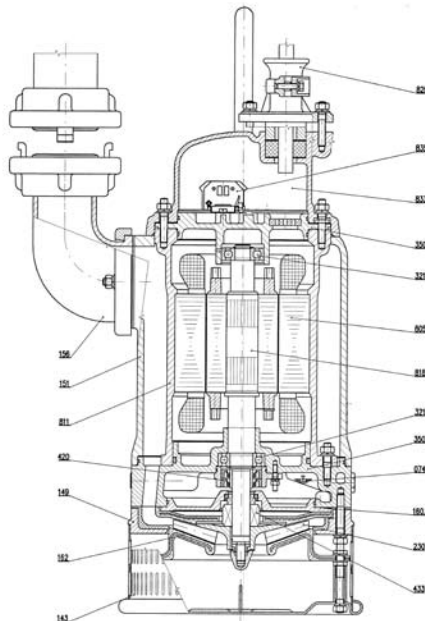

Numbering of positions according to the DIN 24 250

074	-	Oil filling cartridge	321.1
143	-	Suction screen	321.2
149	-	Diffuser	350.1
151	-	Pump jacket	350.2
156	-	Discharge elbow	412
160.1	-	Oil cup bottom	420
162	-	Suction cover	433
162.1	-	Suction cover	550
230	-	Impeller	719

-	Lower bearing	739
-	Upper bearing	805
-	Lower bearing housing	811
-	Upper bearing housing	818
-	Cover sealing	826
-	Radial shaft lip seal ring	833
-	Mechanical seal	835
-	Washer 8, 4	920
-	Complete connecting hose 1m	

## Arrangement option

Employment of the pumps 80-KDFU and 125-KDFU can be enriched with a possibility of series connection of these two pumps, using so called cascade pumping. It is the case when the only one pump cannot cope with a higher delivery head.

Cascade connection requires only little technical adaptation of one of these two pumps. For this adaptation we deliver an appropriate set of parts – an adapted suction cover and a short connecting hose with quick couplers.

The condition of cascade pumping, however, is that a greater part of the total delivery head could be accounted to the upper pump, because otherwise the influence of the upper pump suction effect could cause an irregular operation and reduce the total effect.

## Accessories and equipment

Standard deliveries:

- Fully assembled pump, with 15m of a cable
- Tools ( 1pc of socket wrench 6, 1pc of tubular box spanner 8 with a handle)

By agreement it is possible to deliver:

- Pumps 65-KDFU and 80-KDFU with a circuit breaker and a plug
- Delivery hose in length of 10m (another length on request)
- Accessories for cascade connection

Cascade connection

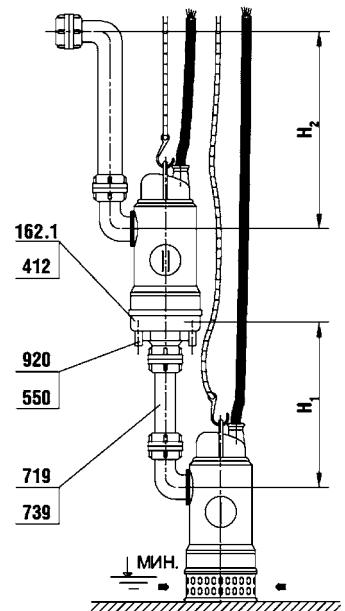

-	Quick coupler
-	Electric motor stator
-	Stator body
-	Electric motor rotor
-	Cable outlet
-	Terminal box cover
-	Terminal box
-	Nut M8

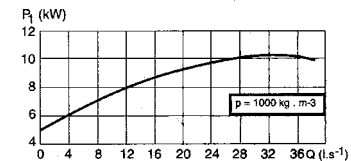
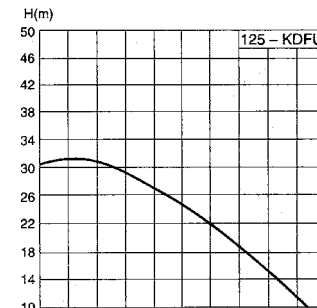
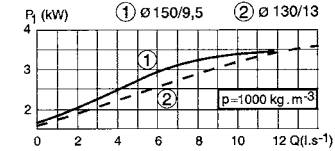
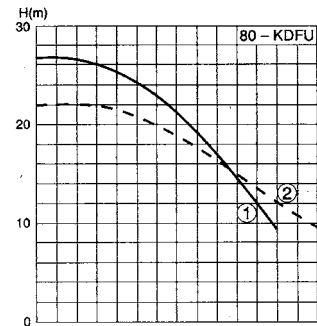
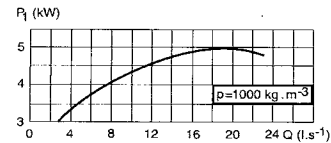
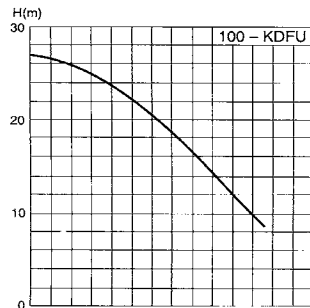
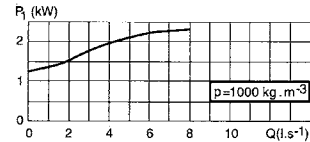
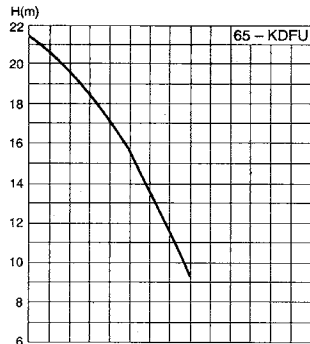

## Performance data

Type			65-KDFU	80-KDFU	100-KDFU	125-KDFU
Impeller			Open, multi-vane			
Pump throughput	Ø	(mm)	5			
Impeller diameter	- standard - on request	(mm) (mm)	130 -	150 130	150 -	170 -
Electric motor			definite-purpose			
Motor rated output	P2	(kW)	1.5	3	3	10
Insulation and protection			Class F; IP 68 $\approx$ 10m			
Voltage	- standard - on request	U (V) U (V)	400 -	400 500	400 -	400 -
Frequency	f	(Hz)	50			
Number of phases			3			
Breaking current, max.	- at voltage 400 V - at voltage 500 V	I (A) I (A)	4	6.5* 7.5** 6	10	19 15.5
Speed	n	(min <sup>-1</sup> )	2,800	2,800	2,800	2,830
Connecting cable	H07 RN - F		6G1.5			6G2.5
Discharge branch	- standard - on request	DN (mm) DN (mm)	52 -	75 52	110 -	
Weight including a cable	m	(kg)	32	43	48	90

The pumps must be protected from overload. The value of breaking current is given in the Table.

\* Impeller Ø 130

\*\* Impeller Ø 150

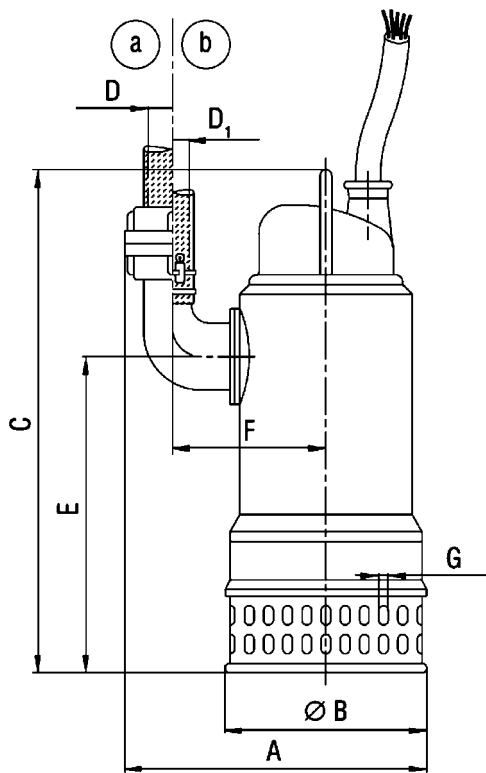

65-KDFU+80-KDFU

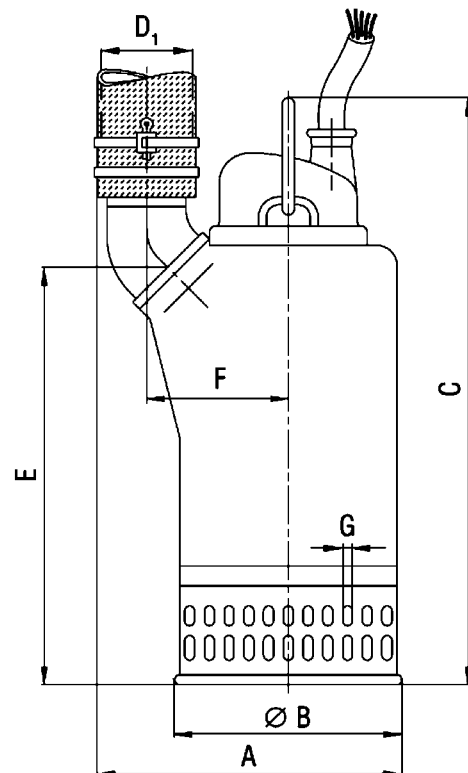

100-KDFU+125-KDFU

## Dimensions

Type	Discharge connection workmanship	~ A	B	~ C	D	D <sub>1</sub>	~ E	~ F	G
65-KDFU	a	330	235	600	DN 52	-	330	160	4
	b	305			-	DN 52			
80-KDFU	a	390	265	650	DN 75*	-	370	163	4
	b	325			-	DN 75*			
100-KDFU	-	380	265	720	-	DN 110	410	190	4
125-KDFU	-	412	320	800	-	DN 110	545	193	8

\*The hose DN 52 - on request (discharge branch change)

We reserve the right to alter specifications and illustrations without prior notice.